



PERFORM, ACHIEVE & TRADE (PAT) SCHEME

Overview of PAT Scheme & outcomes of PAT Cycle-I

Workshop on PAT for Electricity Distribution Companies

Juniper Hall, India Habitat Centre, Lodhi Road, New Delhi

8th August, 2016

Retreating Gangotri Glacier

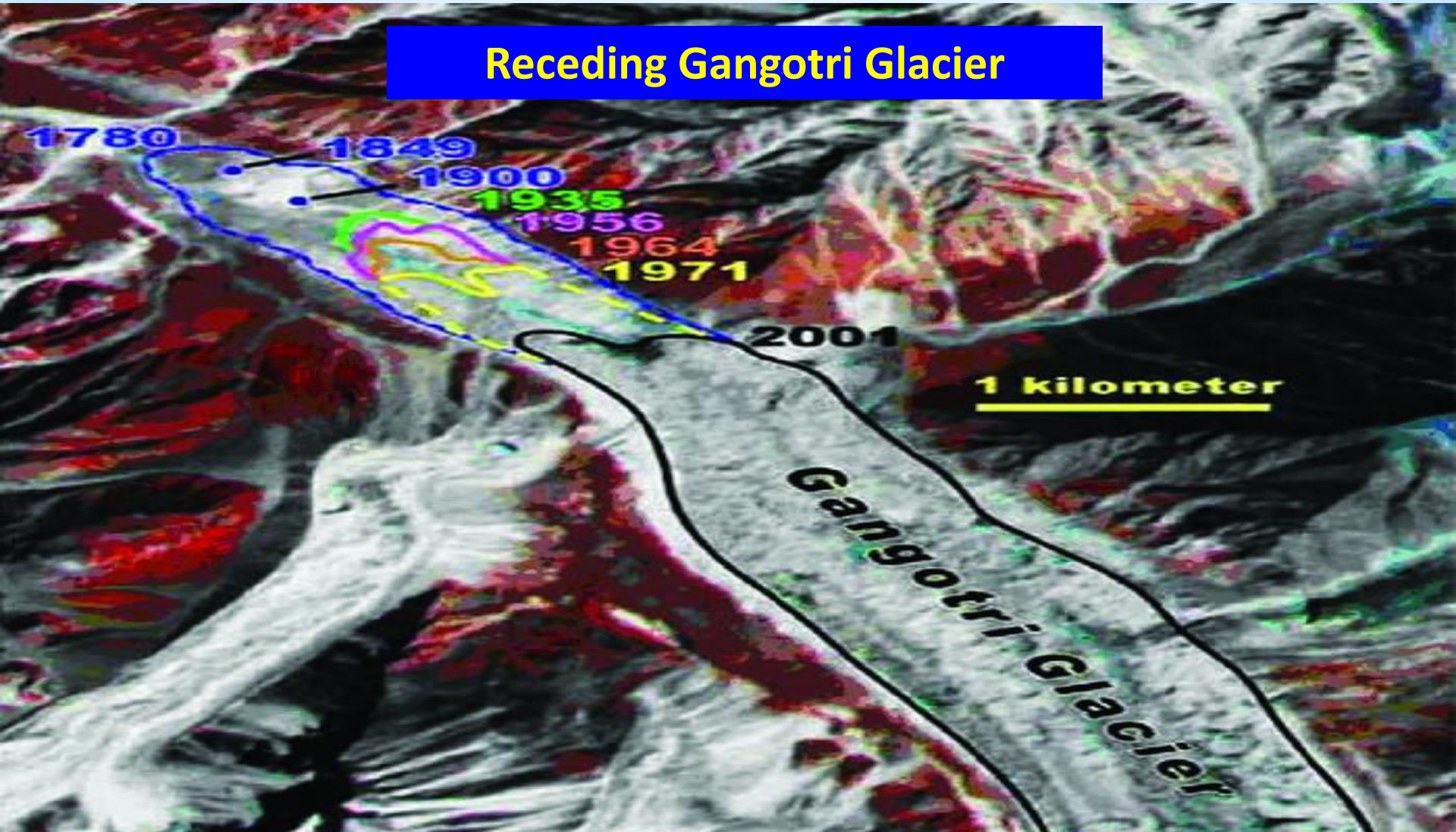

Composite satellite image showing how the Gangotri Glacier terminus has retracted since 1780 (courtesy of NASA, ERDC Data Center, 9 September 2001)

Cloudburst in Uttarakhand, 2013



Flooding in Chennai, 2015



Global Land and Ocean Temperature Anomalies, June

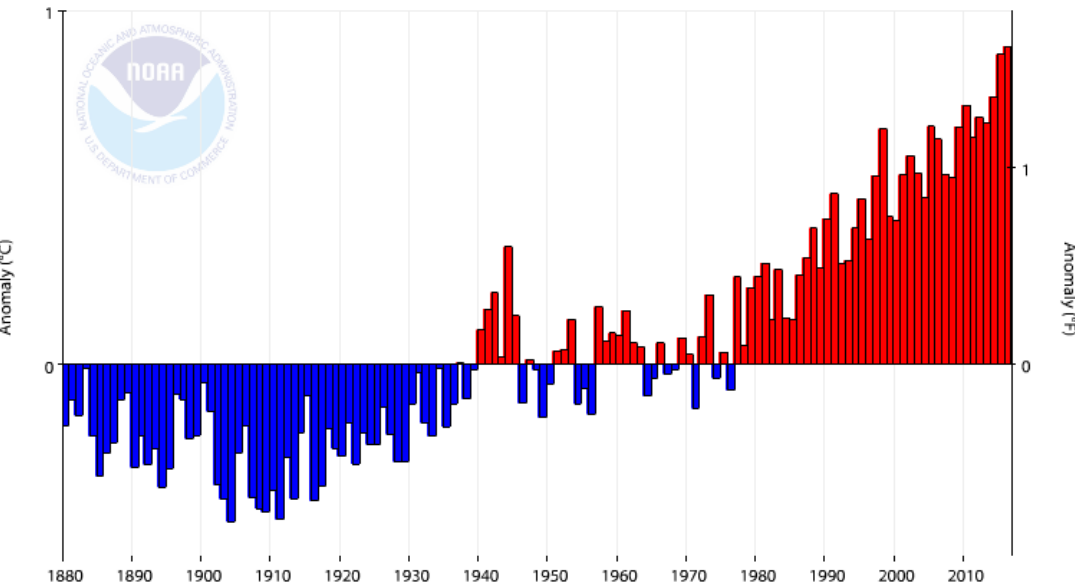

2015 was the warmest year on record, NOAA and NASA



The Arctic Might Lose All Its Ice This Summer For First Time In 100,000 Years, Claims Scientist Peter Wadham, University of Cambridge

Intended Nationally Determined Contributions (INDCs)

- To put forward and further propagate a healthy and **sustainable way of living** based on traditions and values of **conservation and moderation**.
- To adopt a **climate friendly and a cleaner path** than the one followed hitherto by others at corresponding level of economic development.
- To reduce the emissions intensity of its GDP by **33 to 35** percent by **2030** from 2005 level.
- **Enhanced Energy Efficiency**
 - **Industry**
 - **Perform, Achieve and Trade**

World GHG Scenario

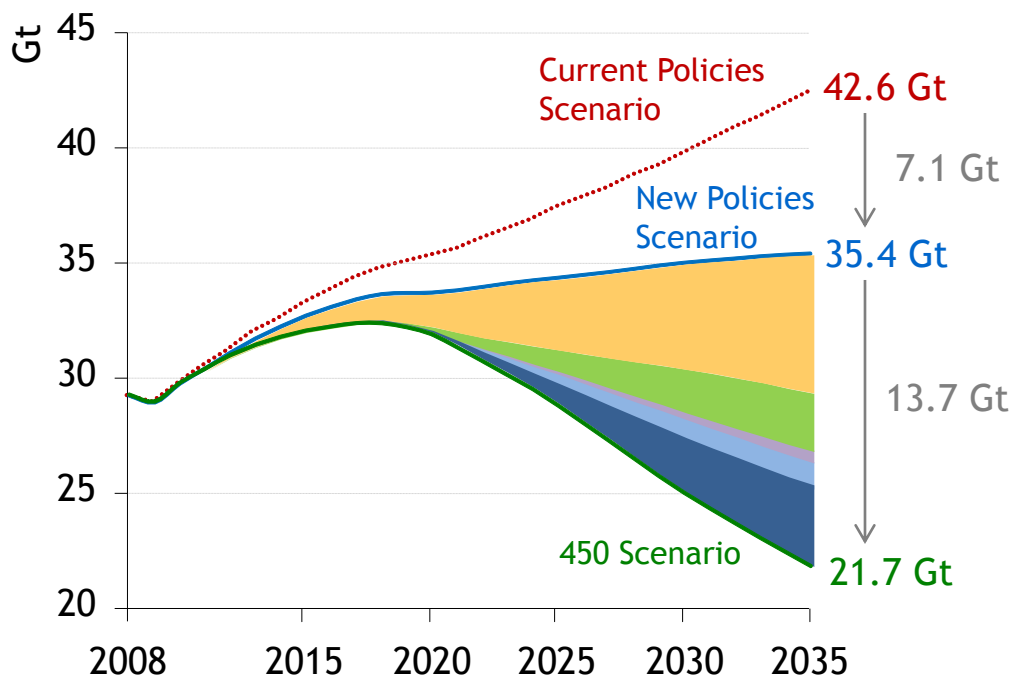

Share of cumulative abatement between 2010-2035

Efficiency	50%
Renewables	18%
Biofuels	4%
Nuclear	9%
CCS	20%

Source: WEO 2010

New Policies Scenario is the central scenario in WEO-2010

> Assumes cautious implementation of recently announced commitments & plans, even if yet to be formally adopted

The 450 Scenario sets out an energy pathway consistent with the goal of limiting increase in average temperature to 2°C

Indian GHG Scenario

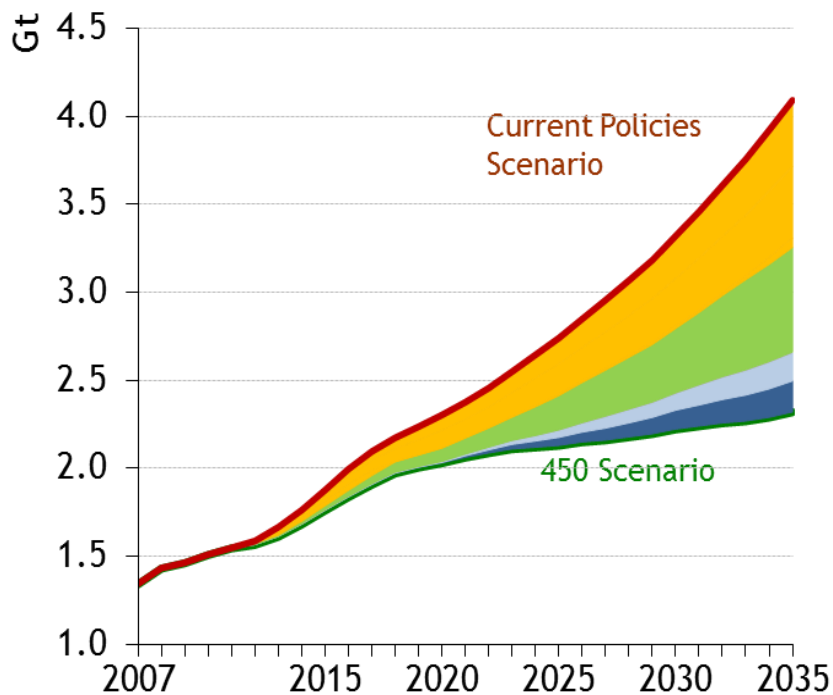

Share of cumulative abatement between 2010-2035

Efficiency	51%
Renewables	32%
Biofuels	1%
Nuclear	8%
CCS	8%

Paris Summit – COP21



Perform, Achieve and Trade (PAT)

National Action Plan on Climate Change (NAPCC)

– Nation Mission for Enhanced Energy Efficiency (NMEEE)

- Perform Achieve and Trade (PAT)
- Market Transformation for Energy Efficiency (MTEE)
- Energy Efficiency Financing Platform (EEFP)
- Framework for Energy Efficient Economic Development (FEEED)

Genesis of PAT

Perform Achieve and Trade (PAT): A regulatory instrument to reduce specific energy consumption in energy intensive industries, with an associated market based mechanism to enhance the cost effectiveness through certification of excess energy saving which can be traded.

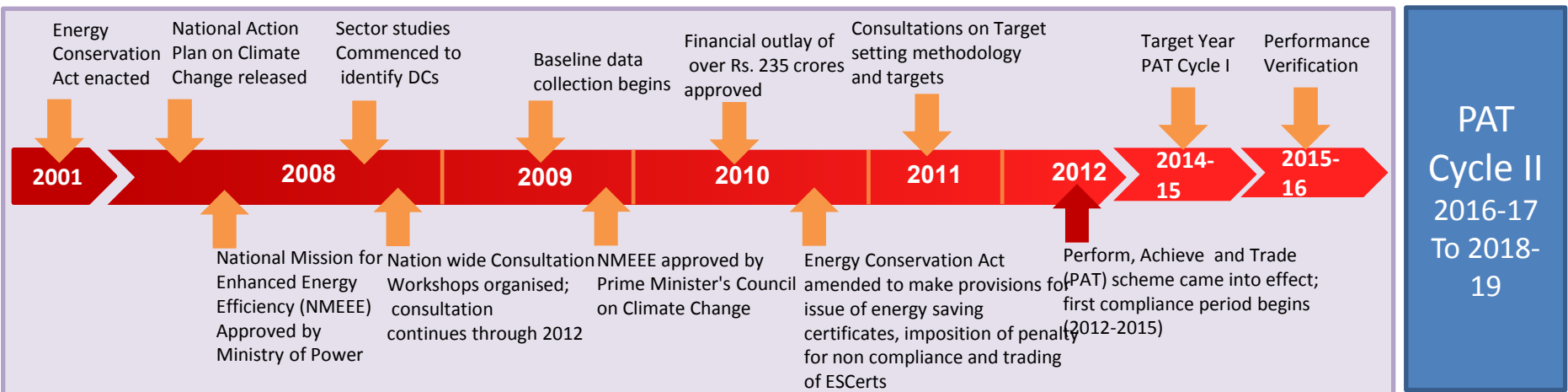

Energy Conservation Rules/Regulations...

- **The Energy Conservation (The Form and Manner for Submission of Report on the Status of Energy Consumption by the Designated Consumers) Rules, 2007 (Section 56, subsection (2), clause(i) of EC Act)**
- **The Energy Conservation (Form and Manner and Time for Furnishing Information with regard to Energy Consumed and Action taken on recommendations of Accredited Energy Auditor) Rules, 2008 (Section 56, sub section (2), clause (h) read with Section 14, clause (k) of EC Act)**
- **The Bureau of Energy Efficiency (Manner and Intervals of Time for Conduct of Energy Audit) Regulations, 2010.**
- **S.O. 1378(E) (27th May, 2014)—In exercise of the powers conferred by clauses (i) and (k) of Section 14 of the Energy Conservation Act, 2001 (52 of 2001), the Central Government, in consultation with the Bureau of Energy Efficiency hereby direct, that every designated consumer shall,—**
 - **(a) get energy audit conducted by an accredited energy auditor, in accordance with the Bureau of Energy Efficiency (Manner and Intervals of Time for Conduct of Energy Audit) Regulations, 2010; and**
 - **(b) furnish to the concerned designated agency, details of information on energy consumed and details of the action taken on the recommendations of accredited energy auditor, in accordance with the Energy Conservation (Form and Manner and Time for Furnishing Information With Regard to Energy Consumed and Action Taken on Recommendations of Accredited Energy Auditor) Rules, 2008.**

Energy Conservation Rules/Regulations...

- In exercise of the powers conferred by clauses (f), (g), (k), (la) and (laa) of sub section (2) of section 56, read with clauses (g) and (o) of section 14, sub-section (1) of section 14A and section 14B of the Energy Conservation Act, 2001 (52 of 2001), the Central Government, in consultation with Bureau, hereby makes the rules for PAT (**GSR 373(E) (31 March, 2016)**)
- In exercise of the powers conferred by clause (g) and (n) of section 14 of the Energy Conservation Act, 2001 (52 of 2001), the Central Government, in consultation with the Bureau of Energy Efficiency, specifies in respect of the designated consumers, the energy consumption norms and standards **S.O. 1264(E) (31 March, 2016)**

PAT Cycle I- Notified Sectors

S. NO.	Sectors	Annual Energy Consumption Norm to be DC (mtoe)	No. of Identified DCs	Annual Energy Consumption (Million toe)	Share Consumption (%)	AppORTIONED Energy Reduction For PAT Cycle-1 (Million toe)
1	Power (Thermal)	30000	144	104.56	63.38%	3.211
2	Iron & Steel	30000	67	25.32	15.35%	1.486
3	Cement	30000	85	15.01	9.10%	0.815
4	Aluminium	7500	10	7.71	4.67%	0.456
5	Fertilizer	30000	29	8.20	4.97%	0.478
6	Paper & Pulp	30000	31	2.09	1.27%	0.119
7	Textile	3000	90	1.20	0.73%	0.066
8	Chlor- Alkali	12000	22	0.88	0.53%	0.054
	Total		478	164.97	100%	6.686

PAT Cycle I- Achievements

S. NO.	Sectors	No. of Identified DCs	Savings (Million toe)
1	Aluminium	10	0.73
2	Cement	75	1.44
3	Chlor- Alkali	22	0.13
4	Fertilizer	29	0.83
5	Iron & Steel	60	2.10
6	Paper & Pulp	26	0.26
7	Textile	82	0.12
8	Thermal Power Plant	123	3.06
	Total	427	8.67

- ▶ Saving of about 8.67 MTOE from the assessed 427 DCs
- ▶ CO₂ mitigation - 31 million tonne

PAT- Way forward (PAT Cycle II)

- Deepening of PAT (existing sectors): Inclusion of more units from existing sectors
 - 89 DCs from (I&S, P&P, Cement, TPP, Chlor-Alkali, Fertilizer and Aluminum and Textiles)
- Widening of PAT: Inclusion of more units from new sectors
 - New sectors: Refinery, Railways and Electricity DISCOMS
 - 84 new DCs

PAT Cycles	No. of Units	Share of total energy consumption (2009-10 Level)	Sectors covered
Cycle I (2012-13 to 2014-15)	478 DCs	36%	8
Cycle II (2016-17 to 2018-19)	621 DCs	50%	11

PAT Cycle II- Notified sectors

Sr. No	Sector	No. of DCs in PAT I	Additional DC in PAT Cycle-II	Total no. of DCs PAT -2
1	Aluminum	10	2	12
2	Chlor-Alkali	22	3	24
3	Textile	90	14	99
4	Pulp & Paper	31	4	29
5	Iron & Steel	67	9	71
6	Fertilizer	29	8	37
7	Cement	85	27	111
8	Thermal Power Plants	144	22	154
9	Refinery	NA	18	18
10	DISCOMS	NA	44	44
11	Railway	NA	22	22
Total				621

PAT Cycle II
Baseline Year: 2014-15
PAT Cycle 2016-2019
Assessment Year: 2018-19

Total Energy
Consumption from 11
sectors 227 mtoe

National Target =
8.869 mtoe at the end
of 2nd PAT Cycle (by
2018-19)

PAT- Salient features

- Regulatory instrument linked with market mechanism
 - Certification of energy saving
- Consultative approach
 - Ministries/DCs/Associations/FIs/Research Organizations
- Outreach/ Capacity Development
 - Workshops/Seminars/ Visits
- “Self – competing”
 - Unit specific targets
- Relative responsibility
 - Less target for more efficient and more for less efficient

Gate-to-Gate concept

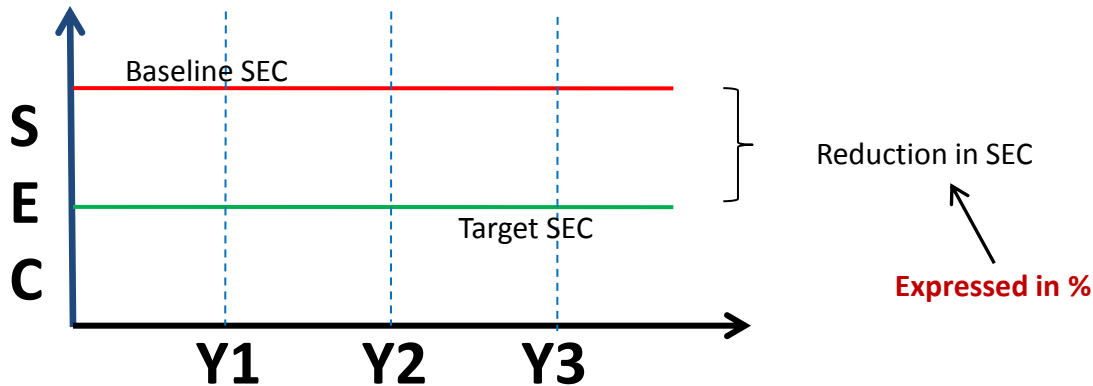
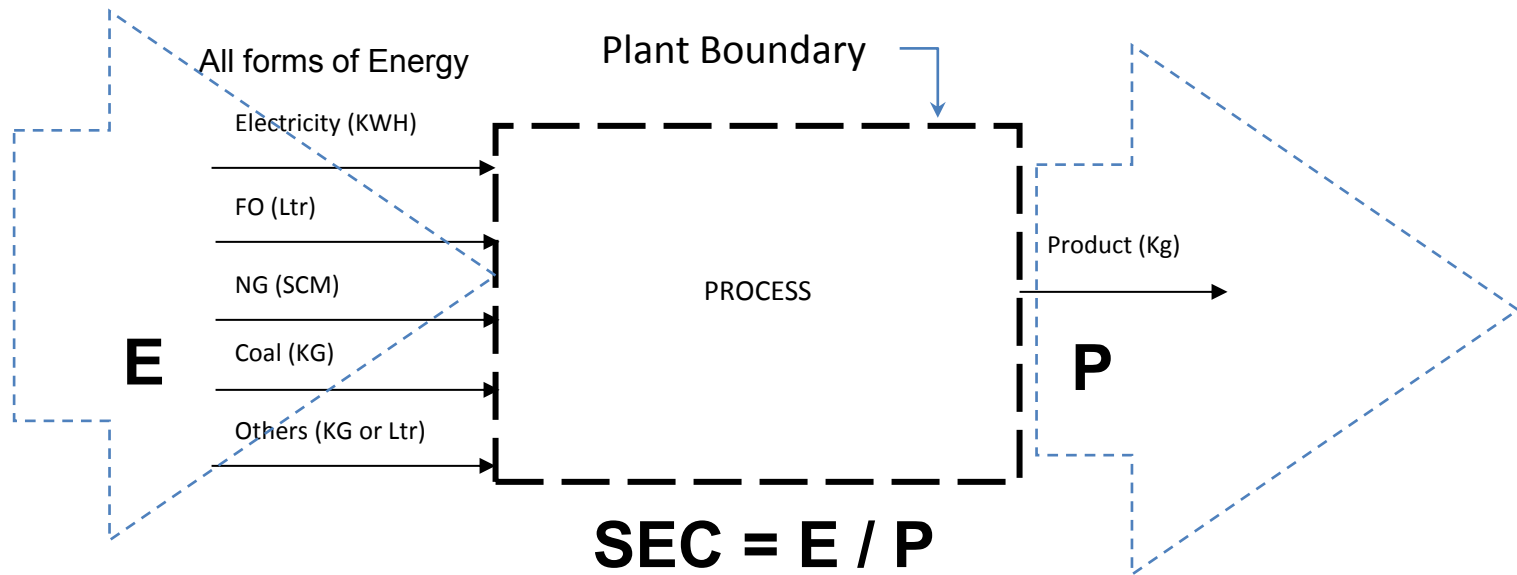

Gate-to-Gate concept

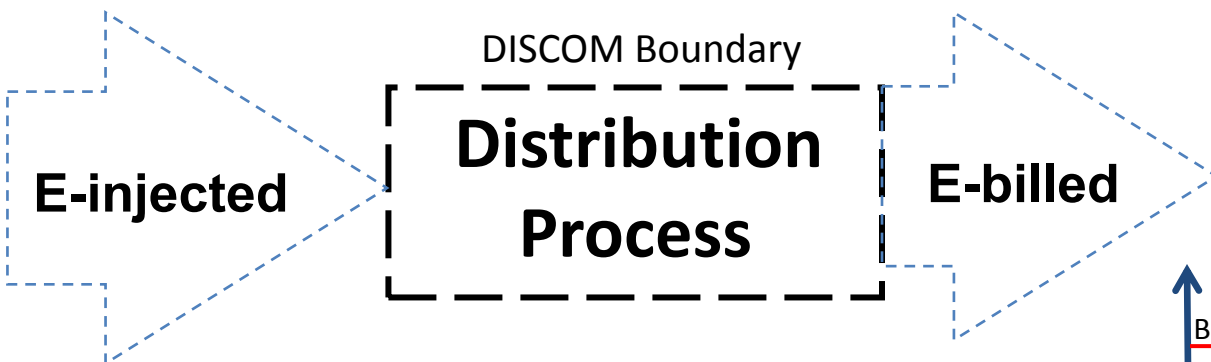

$$\% \text{age T\&D Loss} = E_b / E_i$$

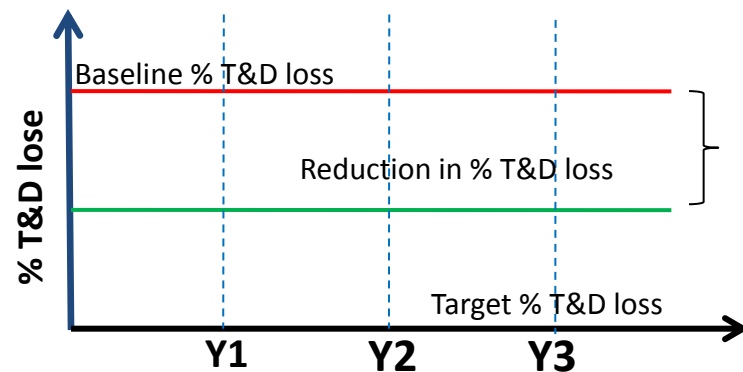

GENERATION

TRANSMISSION

DISTRIBUTION

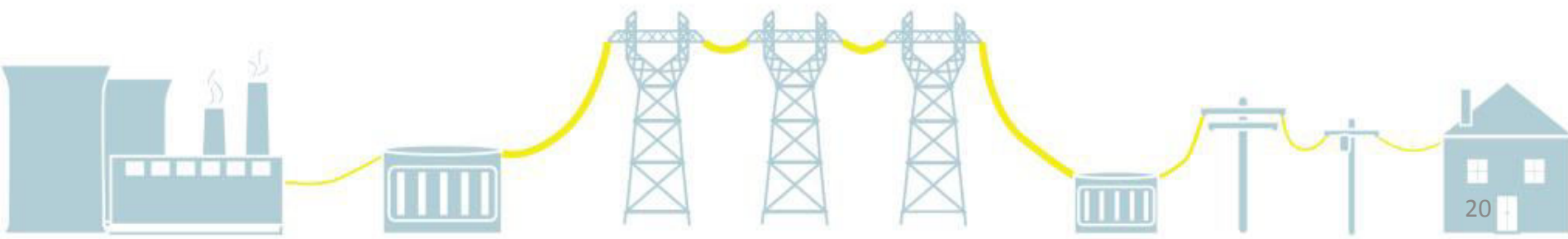

Concept of Target, Compliance, ESCerts & Penalty

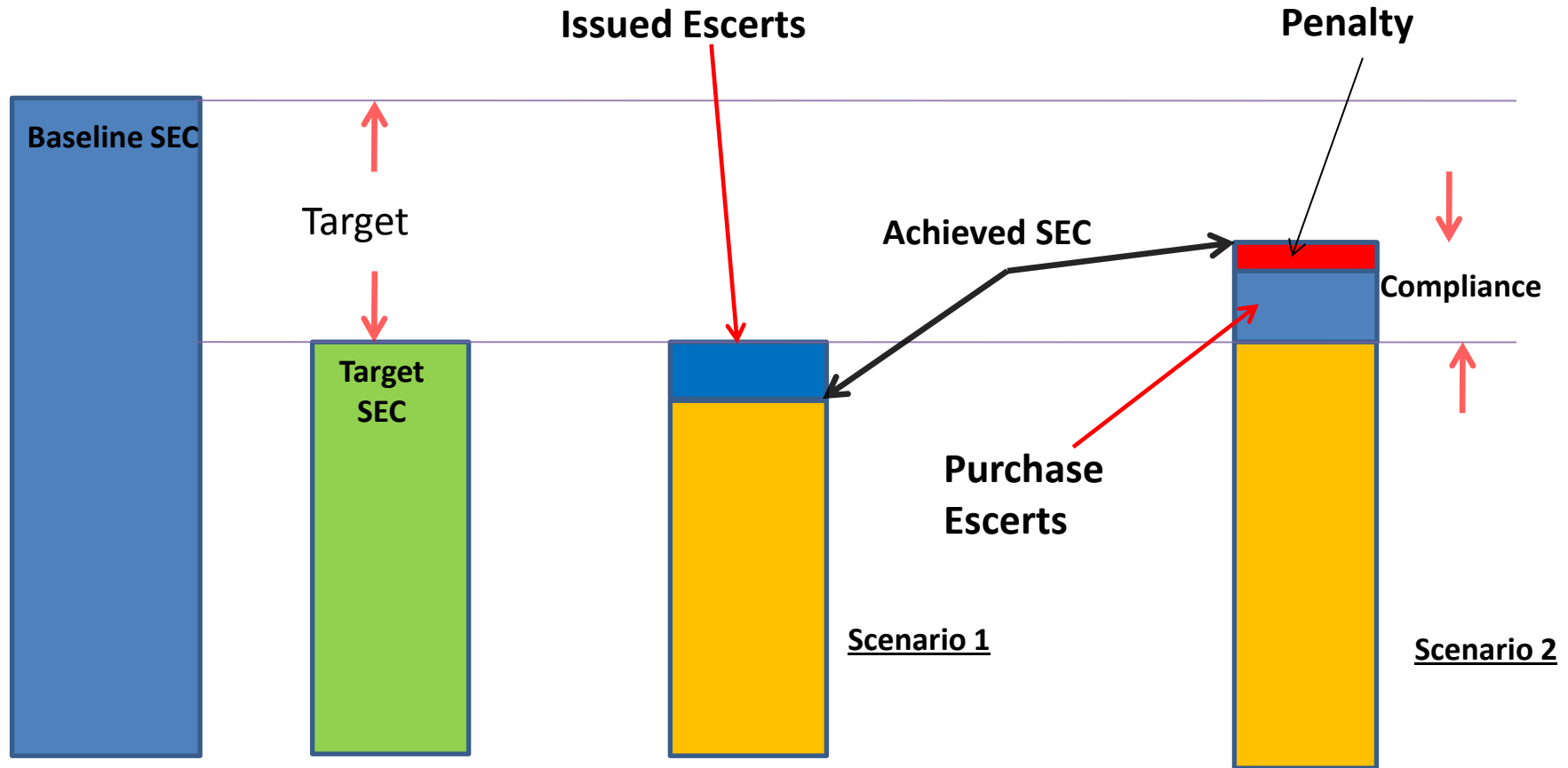

Grouping of DCs

Textile

Based on Major Product

Spinning

Processing

Composite

Fiber

Thermal Power Plants

Based on Fuel Type

Coal/Lignite

Gas

Diesel

DISCOMS

Based on Composition of Consumers

Agriculture/Domestic
/Industry

Urban/Rural

Market Design

- **No. of ESCerts =**
 - **(SEC notified for Target Yr.- SEC achieved in Target Year) X Production in Baseline Year.**

- **ESCerts are issued**
 - **When energy efficiency improvements surpass targets**
 - **With 1 mToE = 1 ESCert**

- **Banking of ESCerts allowed during each cycle**
 - **1st cycle ESCerts to 2nd cycle**
 - **2nd cycle ESCerts to 3rd cycle**

Price of ESCerts

$$P = Wc \times Pc + Wo \times Po + Wg \times Pg + We \times Pe$$

Where-

P = Price of one metric ton of oil equivalent (1 mtoe);

Pc = Price of F-grade coal declared by Ministry of Coal;

Po = Price of fuel oil as declared by Ministry of Petroleum & Natural Gas;

Pg = Price of gas as declared by Ministry of Petroleum & Natural Gas;

Pe = Price of electricity;

Wc = Weightage of coal;

Wo = Weightage of oil;

Wg = Weightage of gas;

We = Weightage of grid electricity

The weightage of coal (Wc) in the Indian energy mix shall be worked out as under:

$$Wc = \frac{\text{Amount of coal consumed in 478 DCs (in mtoe)}}{\text{Total energy consumed in 478 DCs (in mtoe)}}$$

Stakeholders

Regulator

MoP

Administrator

**Bureau of
Energy
Efficiency**

Implementer

**Designated
Consumer**

**State Nodal
Agency /
Adjudicator**

**State
Designated
Agency/ SERC**

Verifier

**Empanelled
Accredited
Energy
Auditor**

**Trading Regulator,
Registry**

**CERC/
POSOCO**

Institutional Structure

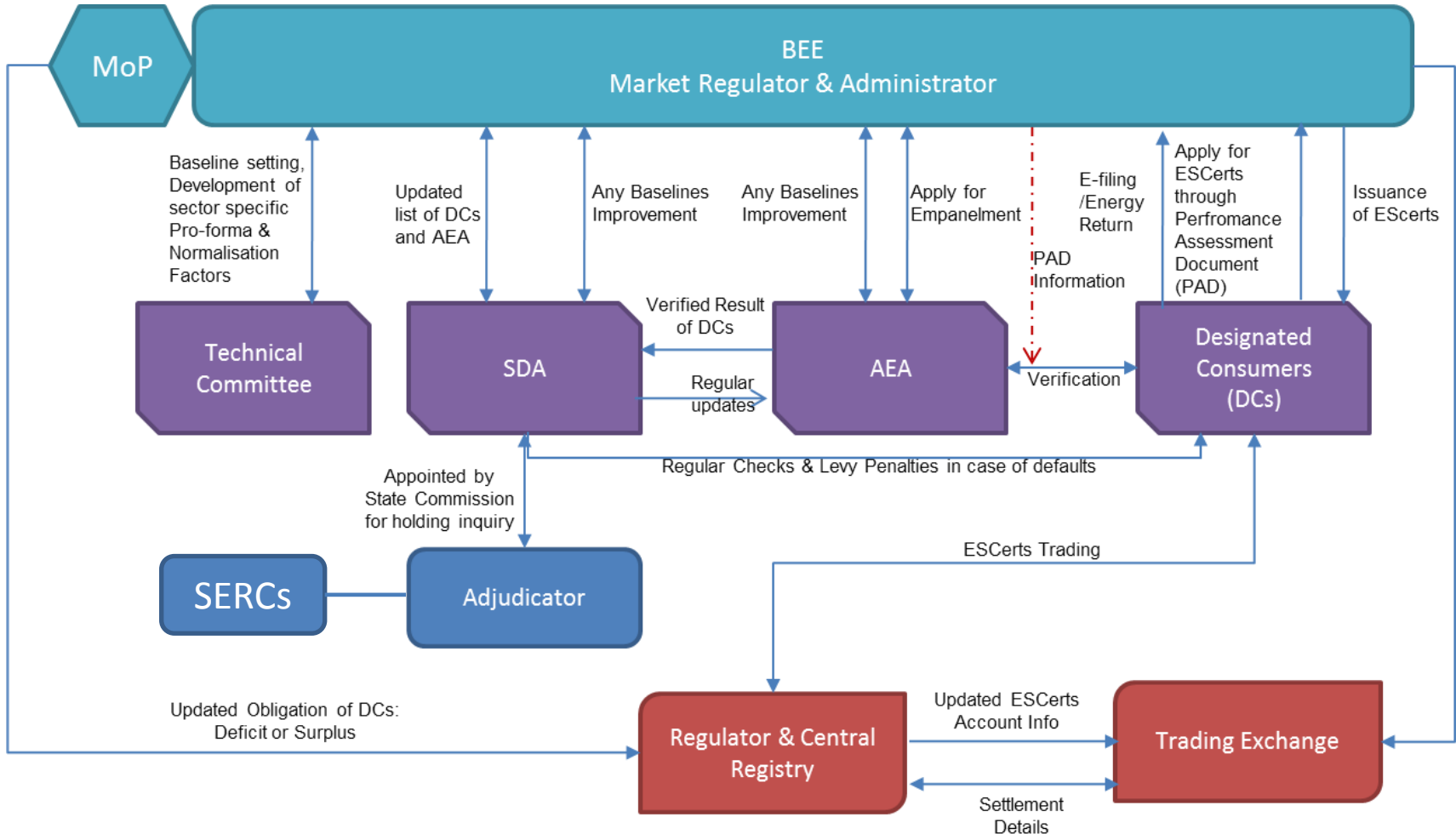

Process Flow for Issuance of ESCerts

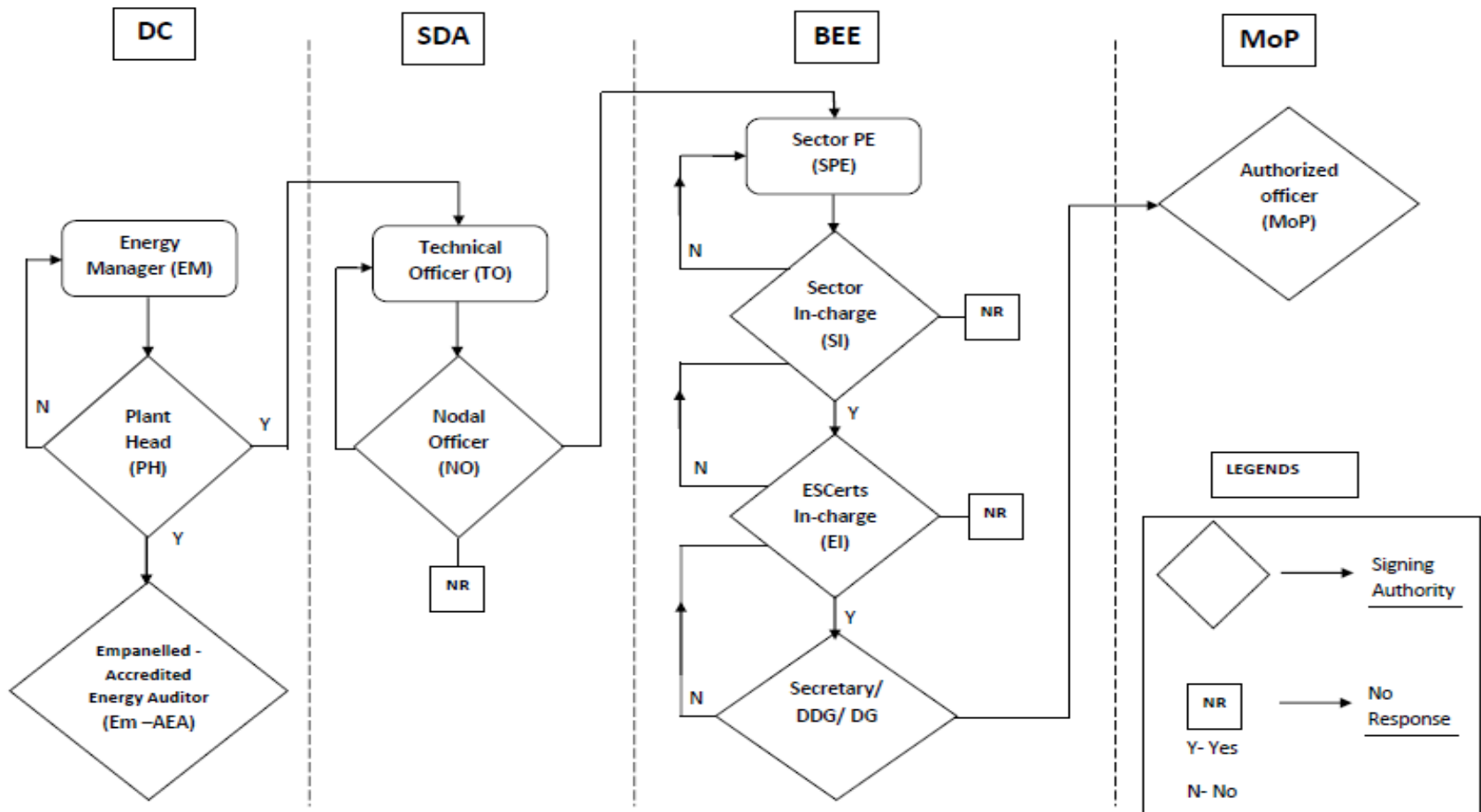

NR: No Response – Notification is issued to the head of the department and to the next officer in the channel.

Trading for Compliance

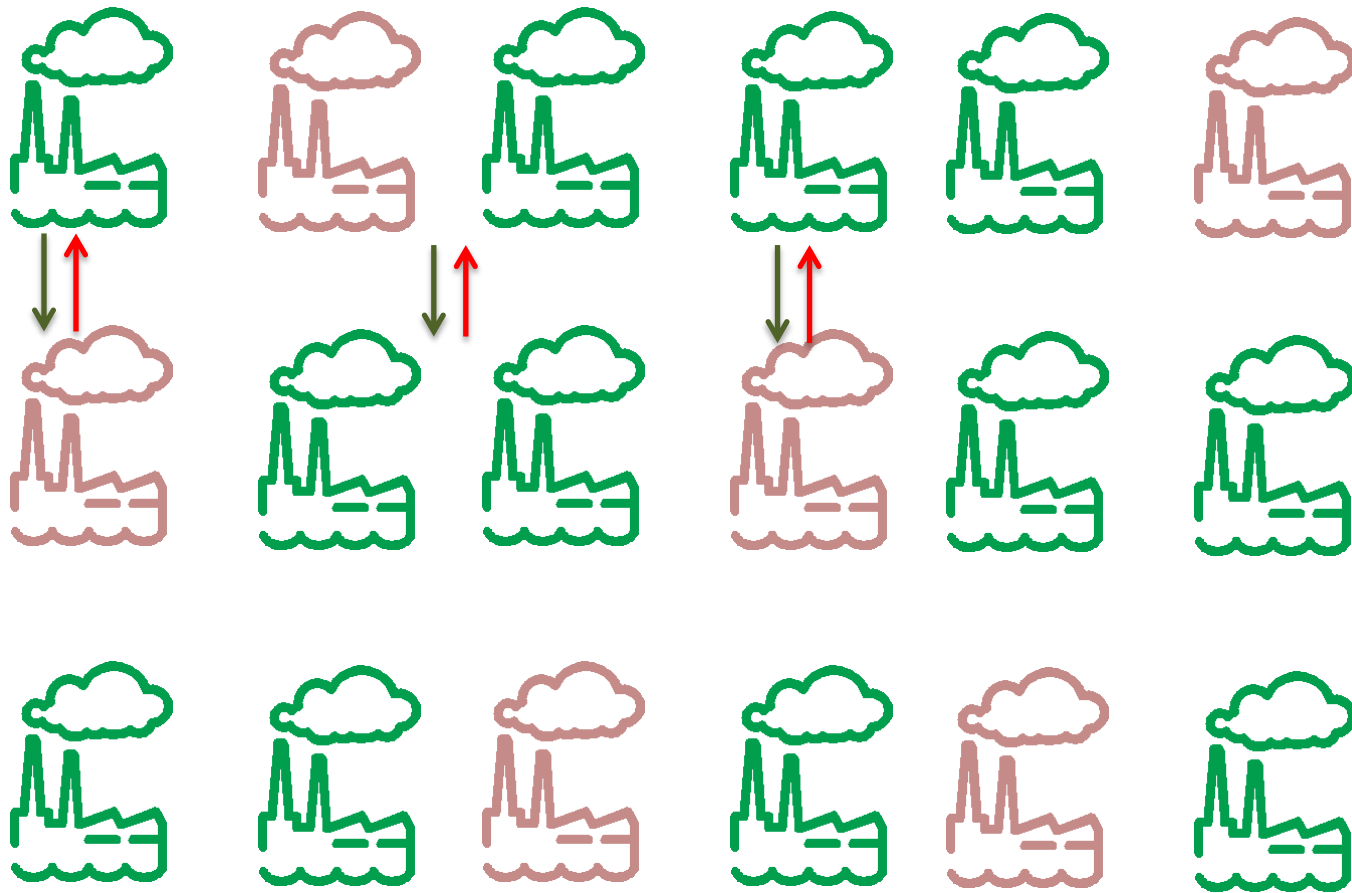

PAT- Challenges

- Reporting
- Normalization
- Integration
- Documentation
- Communication
- Adoption
- Evaluation

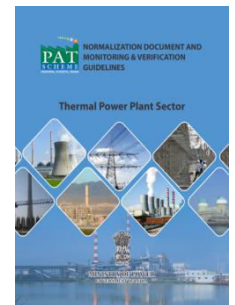
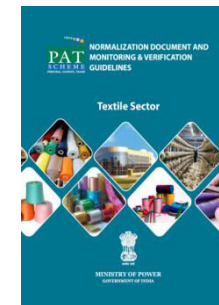
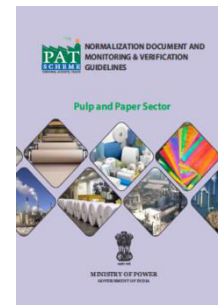
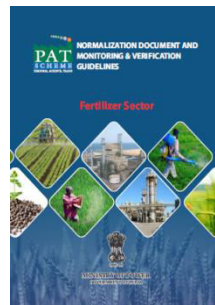
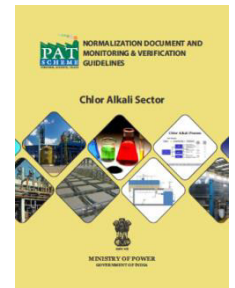
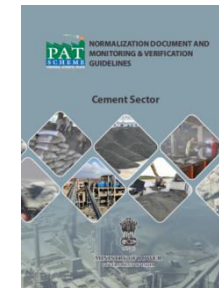
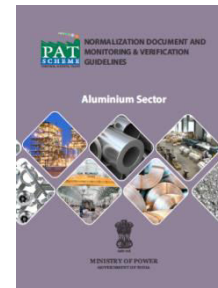
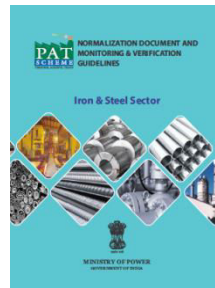

PAT Cycle I Experience

- Amendments in the EC Act
- Requires changes in the timelines
 - Notified timeline for comprehensive monitoring, reporting and verification was extended
 - Deadline for submission of Performance Assessment Document extended by 45 days
- Need to link Inspection Rules, 2010 with Check verification under PAT to increase the domain of SDAs in the process of check verification
- Capacity of stakeholders
 - Need for building of Capacity of AEAs/SDAs/BEE desired

PAT Cycle I Experience

- Removal of rules related to early issuance of ESCerts
 - No DCs applied for early issuance
 - Proposal for rolling cycle
- Changes in the target setting methodology
 - To factorize the historical trend of sectoral efficiency improvement
 - National Policy objectives
 - Recognition of Global best sector/DCs
- Changes in the baseline setting methodology
 - To accommodate the variations in capacity utilization
 - Single year based baseline fixation
- Normalization factors
 - Need to provide legal sanctity to normalization factors

Amendment in Energy Conservation Rules, 2012

Major Insertion/modification

Rule 3

aa) Identification of Global Best Sector

(ab) Target Setting condition for Non-global best sector

(ac) Incentivise the top 10% DCs of the sectors

1. Distinction is made between the Global best sector and non-global best sector
2. To provide motivation to the top 10% of the DCs in a sector/sub-sector to improve their energy efficiency.

Rule 6

Sub-rules (8), (9), (10) and (11) inserted for Solid Fuel sampling, testing and check testing

To ensure proper verification and authentication of the Solid Fuel used

Monthly Testing from NABL Lab, Random Crosschecking from agencies appointed by BEE/SDA

Rule 6

(ba) follow the latest guidelines issued by Bureau from time to time

To provide legal sanctity to M&V guidelines

Amendment in Energy Conservation Rules, 2012

Major Insertion/modification

Rule 16

Value of ESCerts for the year 2014-15 as Rs. 10968

To provide the exact value of one tonne of oil equivalent

Rule 13

Insertion of Schedule II for incorporation of Normalisation Factors

The schedule provides formulae for Normalisation

Rule 10

Action on Professional mis -conduct for Verification/Check verification

Inclusion of enforcement provisions under Regulation 2010 in the PAT Rules

Rule 4

Provisions are made to collect data from meters sources

Amendment in Energy Conservation Rules, 2012 Major Insertion/modification

Rule 16

Value of ESCerts for the year 2014-15 as Rs. 10968

To provide the exact value of one tonne of oil equivalent

Rule 13

Insertion of Schedule II for incorporation of Normalisation Factors

The schedule provides formulae for Normalisation

Rule 10

Action on Professional mis -conduct for Verification/Check verification

Inclusion of enforcement provisions under Regulation 2010 in the PAT Rules

Rule 4

Provisions are made to collect data from meters sources

Key Timelines: Proposed

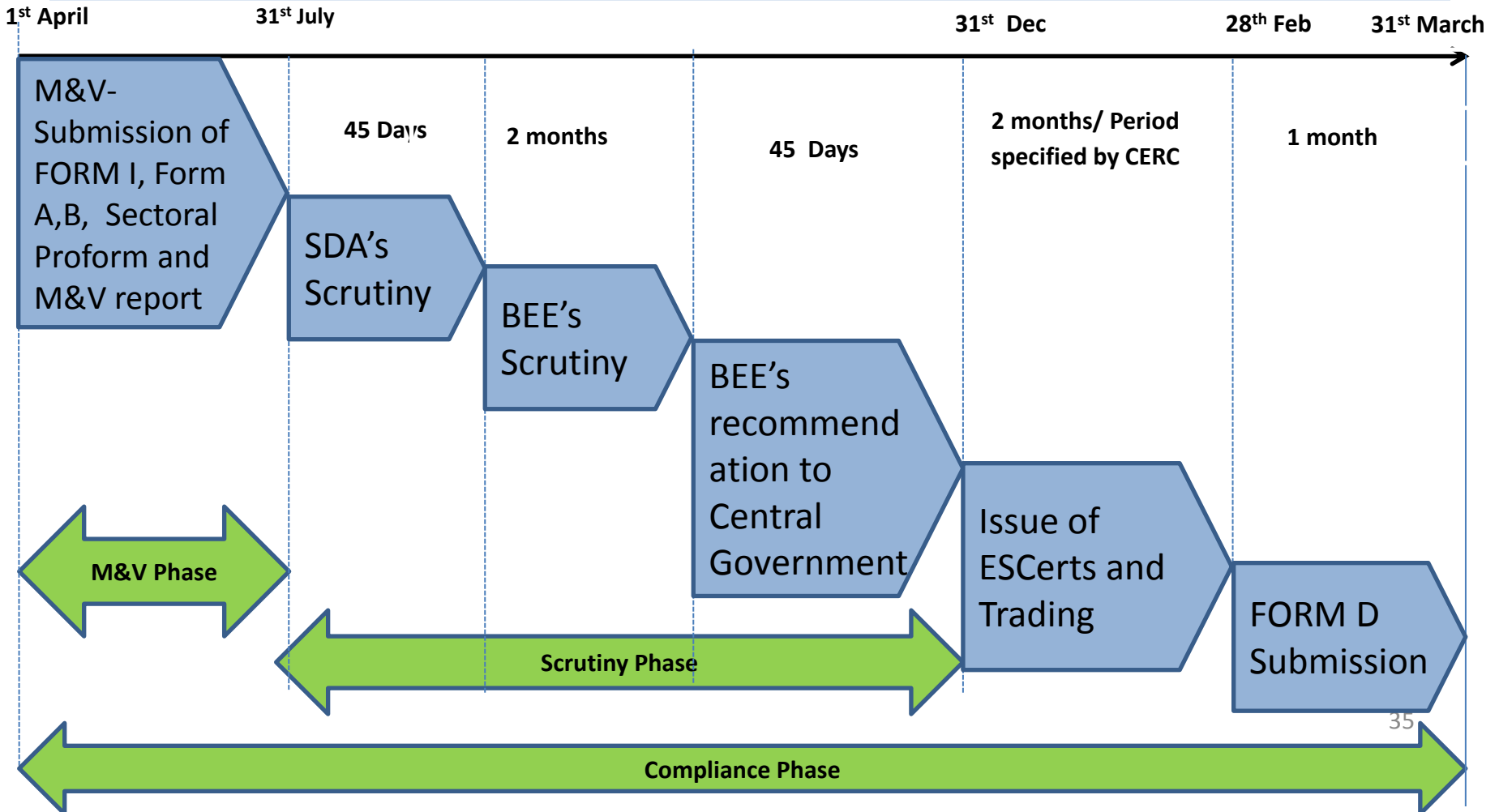

Normalization

“Normalisation” means a process of rationalization of energy and production data of Designated Consumer to take into account changes in quantifiable terms that impact of energy performance under equivalent conditions’.

- It is a streamlining process by which any DC is not subjected to undue advantage or disadvantage due to factors beyond the control of the DC

Process

- Formation of sectoral/sub-sectoral technical committee
- Consultation with stakeholders
- Identification of factors
- Integration with reporting format - proforma
- Validation with real data

PAT- Way forward (PAT Cycle II +)

▶ Orientation Workshops (10) for new DCs

Workshops for filling up Data I the Pro-forma and Target Fixation methodology at SDAs

▶ Regional Workshops for both DCs (New and Old)

▶ Sector specific workshops at Delhi, Mumbai, Bangalore and Kolkata

▶ Regional workshops with SDAs and SERCs on Penalty and Adjudication

▶ Initiation of Rolling cycle

- ▶ PAT III – Petrochemicals and 24 hour usage building to be included

PAT- Way forward (PAT Cycle II +)

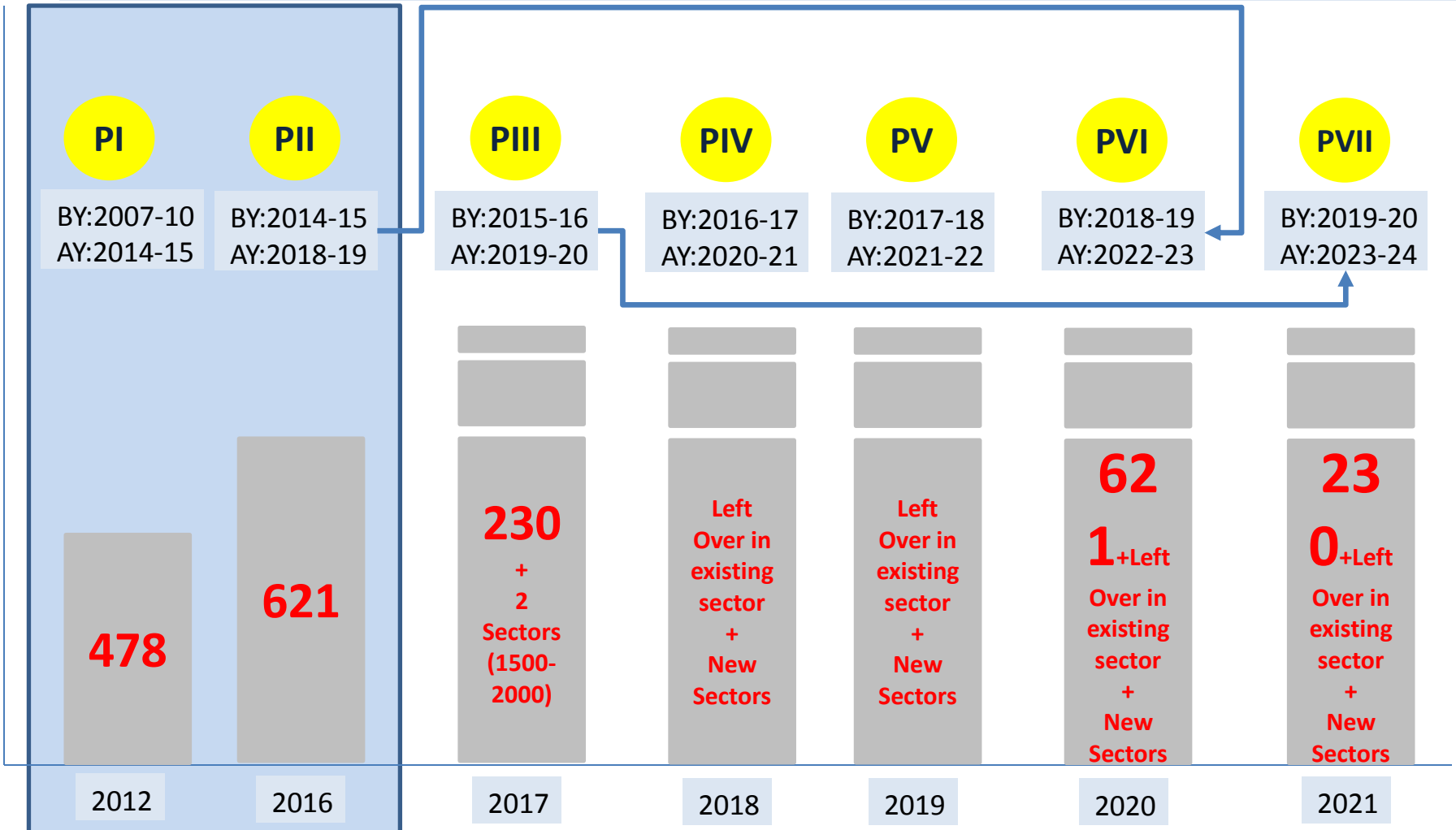



Thank you